

Model			SMH(18)E32DKO	
Product Code			CB228W08620	
Power supply	Rated Voltage	V~	220-240	
	Rated Frequency	Hz	50	
	Phases		1	
Cooling capacity		W	5200	
Heating capacity		W	5400	
Cooling Power Input		W	1450	
Heating Power Input		W	1300	
Cooling Current Input		A	6.43	
Heating Current Input		A	5.77	
Rated Power Input		W	1.78	
Rated Current		A	7.9	
SEER		W/W	3.59	
SCOP		W/W	4.15	
Outdoor Unit	Compressor Trademark		ZHUHAI LANDA COMPRESSOR CO.,LTD	
	Compressor Model		QXF-B141ZF030A	
	Compressor Refrigerant Oil Type		68DA	
	Compressor Type		Inverter Rotary	
	L.R.A		A	25
	Compressor Rated Load Amp (RLA)		A	6.5
	Compressor Power Input		W	1410
	Compressor Thermal Protector			1NT11L-6233 or HPC 115/95 or KSD115°C
	Throttling Method			Electron expansion valve
	Cooling Operation Ambient Temperature Range		°C	18~43
	Heating Operation Ambient Temperature Range		°C	-15~24
	Condenser Material			Aluminum Fin-copper Tube
	Condenser Pipe Diameter		mm	Φ9.52
	Rows-Fin Gap(mm)		mm	19.05X22
	Coil length (l) X height (H) X coil width (L)		mm	760X44X559
	Fan Motor Speed (rpm)		rpm	800/900
	Output of Fan Motor		W	30
	Fan Motor RLA		A	0.39
	Fan Motor Capacitor		μF	/
	Air Flow Volume of Outdoor Unit		m ³ /h	800/900
	Fan Type-Piece			Axial-flow
	Fan Diameter		mm	Φ438-116
	Defrosting Method			Automatic Defrosting
	Climate Type			T1
	Isolation			I
	Moisture Protection			IPX4
	Permissible Excessive Operating Pressure for the Discharge Side		MPa	4.3
	Permissible Excessive Operating Pressure for the Suction Side		MPa	2.5
	Dimension (WXHxD)		mm	899X378X596
	Dimension of Package (LXWXH)		mm	945X417X630
Dimension of Package(LXWXH)		mm	948X420X645	
Net Weight		kg	43	
Gross Weight		kg	46	
Refrigerant Charge			R32	
Refrigerant Charge		kg	1.05	

3. Outline Dimension Diagram

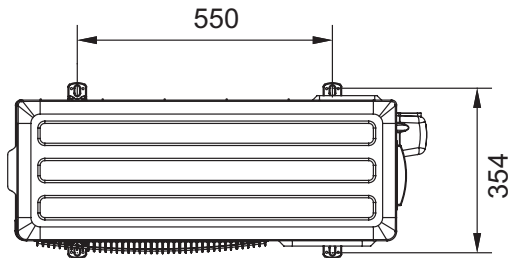
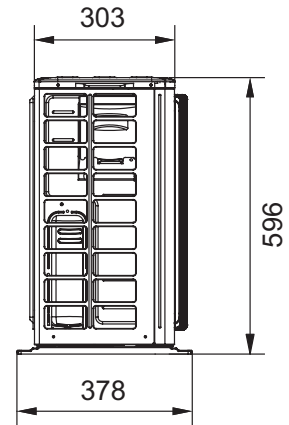
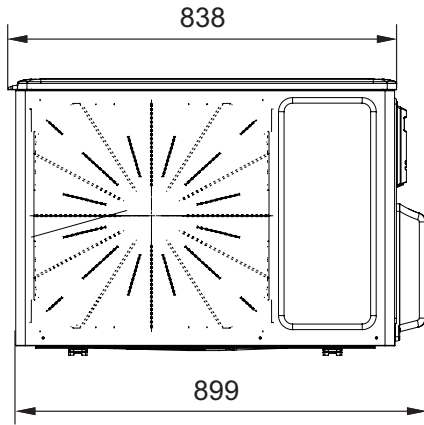

Unit:mm